

**CONTROL
TECHNIQUES**

SERVO MOTOR SERIES

UNIMOTOR HD

**High Dynamic AC brushless
servo motor**



055 to 190 Frames
0.72 Nm to 85 Nm
(255 Nm Peak)

Nidec

All for dreams

Unimotor hd

Unimotor hd is a high dynamic brushless AC servo motor range designed for use in pulse duty applications where rapid acceleration and deceleration are required. The motors are available in frame sizes from 055 to 190.



Reliability and innovation

Unimotor hd is designed using a proven development process that prioritises innovation and reliability. This process has resulted in a market leading reputation for both performance and quality.



Matched motor and drive combinations

Drives and motors from Control Techniques are designed to function as an optimized system. Unimotor hd is the perfect partner for Digitax and Unidrive.



Accuracy and resolution to suit your application requirements

Choosing the right feedback device for your application is critical in getting optimum performance. Unimotor hd has a range of feedback options that offer different levels of accuracy and resolution to suit most applications::

- Resolver: robust for extreme applications and conditions – low accuracy, medium resolution
- Incremental encoder: high accuracy, medium resolution
- Inductive/capacitive SinCos/Absolute: medium accuracy, high resolution
- Optical/SinCos/Absolute: high accuracy, high resolution
- Single turn and multi-turn: Hiperface and EnDat protocols supported



The ultimate motor and drive combination

Control Techniques offer drive and motor combinations that provide an optimized system in terms of ratings, performance, cost and ease of use.

Unimotor hd motors fitted with high resolution SinCos or Absolute encoders are pre-loaded with the motor “electronic nameplate” data during the manufacturing process. This data can be read by any of our servo drives and used to automatically optimize the drive settings.

This feature simplifies commissioning and maintenance, ensures consistent performance and saves time.



Features

Unimotor hd is suitable for a wide range of industrial applications, due to its extensive range of features:

- Torque range: from 0.72 Nm to 85 Nm
- High torque to inertia ration for high dynamic performance
- Compact but powerful
- High energy dissipation parking brakes
- IP65 conformance; sealed against water spray and dust when mounted and connected
- Segmented stator design
- World class performance
- Supported by rigorous testing for performance and reliability
- Winding voltages for inverter supply of 400 V and 220 V
- Rated speeds from 1,000 to 6,000 rpm
- Larger shafts to increase torsional rigidity
- Thermal protection by PTC thermistor/optional KTY84.130 sensor



Custom built motors

As part of our commitment to you, we can design special products to meet your application specific requirements.

Custom built motors are identified by the code -S*** added to the end of the part number and can include custom shafts, connections or coatings.

e.g. SPZ - Motor is left unpainted
SON - Motor is fully painted

(* Indicates additional letters)



Unimotor hd and Digitax HD

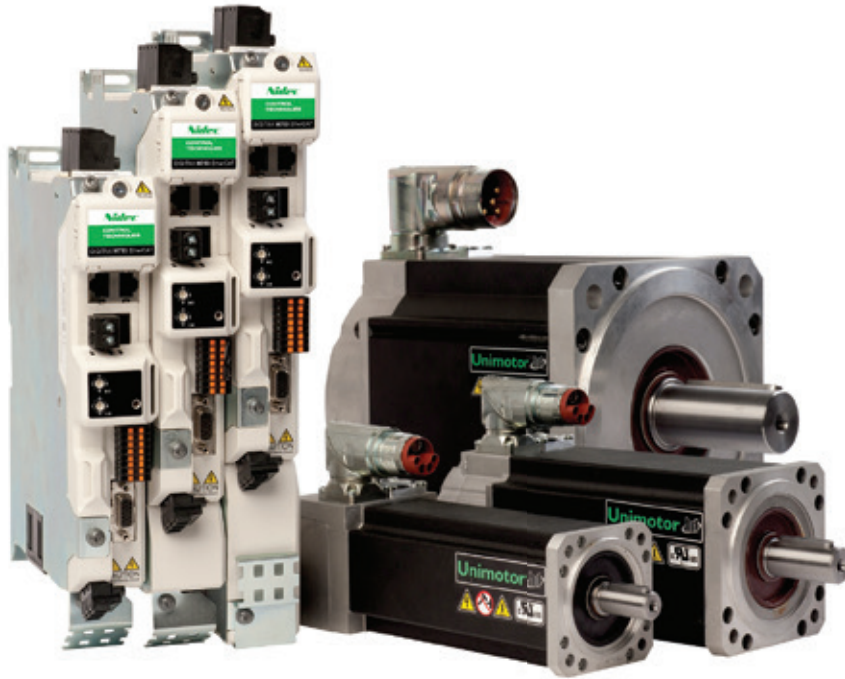

Quick reference table

Frame size	PCD (mm)	Unimotor hd													
055	063	0.72		1.65											
		0.14		0.36											
067	075	1.45		3.70											
		0.30		0.75											
089	100	3.20		8.00											
		0.87		2.34											
115	130	5.8		18.8											
		2.42		8.38											
142	165	10.0		38.0											
		6.50		27.2											
190	215	52.0		85.0											
		54.6		103.5											
Stall	(Nm) 0	0.5	1.0	3.0	5.0	8.0	10.0	15.0	20.0	30.0	60.0	85.0			
Inertia	(kg.cm2) 0	0.1	0.2	0.7	1.5	2.5	6.5	8.0	9.0	20.0	60.0	103.5			

Conformance and standards



Ordering information – D + 10 lead time

Use the information below in the illustration to create an order code for a Unimotor hd.

089	UD	B	30	0	B
Frame size	Motor voltage	Stator length	Rated speed	Brake	Connection type
	055 - 115 frame	055 frame	055 - 142 frame	055 - 142 frame	Size 1
055	ED = 220 V	A - B	*20 = 2000 rpm	0 = Not fitted (Std)	B = Power and signal 90° rotatable
067		067 frame	30 = 3000 rpm	5 = Parking brake (fibre)	
089		A	*115UDD20 only	6 = Parking brake (resin) ¹	
115		089 frame		6 brake not available on 055 frame ¹	
142		C			
	055 - 142 frame	055 frame			
	UD = 400 V	A - C		Express availability motors, available in ten days ex works	
		067 frame			
		B			
		089 frame			
		B - C			
		115 frame			
		B - D			
	142 frame				
		C			

Ordering information – standard lead time

Additional options are available upon request but may require a longer lead time to complete, please check with the Automation Center.

067	UD	B	30	0	B
Frame size	Motor voltage	Stator length	Rated speed*	Brake	Connection type**
		055 frame	055 - 067 frame	055 - 190 frame	Size 1
055	ED = 220V	A - C	30 = 3000 rpm	0 = Not fitted (Std)	B = Power and signal 90° rotatable
067	UD = 400V	067 frame	60 = 6000 rpm	5 = Parking brake (fibre)	D = Single cable, power & signal combined, 90° rotatable
089		A - C	089 frame	6 = Parking brake (resin) ¹	
115		089 frame	30 = 3000 rpm	X = Special	Size 1.5
142		A - C	40 = 4000 rpm	6 brake not available on 055 frame ¹	
190		115 frame	60 = 6000 rpm		J = Power and signal 90° rotatable
		B - D	115 frame		E = Single cable, power & signal combined, 90° rotatable
		142 frame	20 = 2000 rpm		
		C - E	30 = 3000 rpm		
		190 frame	142 frame		
		C / D / F	10 = 1000 rpm		
			15 = 1500 rpm		
			20 = 2000 rpm		
			30 = 3000 rpm		
			190 frame		
			10 = 1000 rpm		
			15 = 1500 rpm		
			20 = 2000 rpm		

* Not all speeds are available on all motors

** Single cable only must be fitted with KTY thermistor and is only available with certain feedback options. Please check before ordering.

A	CA		A
Output shaft	Feedback device		Inertia
055 - 142 frame	055 - 067 frame		055 - 142 frame
A = Key	AR = Resolver		A = Standard + PTC Thermistor
F = Key and half key supplied separately ²	CR = Incremental Encoder	R35i	
	EM = Inductive EnDat SinCos Multi-turn	EQI 1130	
	089 - 142 frame		
	AE = Resolver		
	CA = Incremental Encoder	CFS50	
	EC = Inductive EnDat SinCos Multi-turn	EQI 1331	
	EB = Optical EnDat SinCos Single-turn	EQN 1325	
	RA = Optical Hiperface SinCos Multi-turn	SRM 50	

A	CA		A
Output shaft	Feedback device		Inertia
055 - 190 frame	055 - 067 frame		055 - 190 frame
A = Key	AR = Resolver		A = Standard + PTC Thermistor
B = Plain shaft	CR = Incremental Encoder	R35i	C = Standard + KTY Thermistor
E = Key with half key fitted ²	EM = Inductive EnDat SinCos Multi-turn	EQI 1130	E = Standard + PTC Thermistor + Lifting brackets
F = Key and half key supplied separately ²	FM = Inductive EnDat SinCos Single-turn	ECI 1118	
	TL = Optical Hiperface SinCos Multi-turn	SKM 36	
	UL = Optical Hiperface SinCos Single-turn	SKS 36	
	XX = Specials		
	089 - 190 frame		
	AE = Resolver		
	CA = Incremental Encoder	CFS50	
	EC = Inductive EnDat SinCos Multi-turn	EQI 1331	
	FC = Inductive EnDat SinCos Single-turn	ECI 1319	
	EF = Inductive EnDat Multi-turn FS	EQI 1331FS	
	FF = Inductive EnDat Single-turn FS	ECI 1319FS	
	RA = Optical Hiperface SinCos Multi-turn	SRM 50	
	SA = Optical Hiperface SinCos Single-turn	SRS 50	
	EB = Optical EnDat SinCos Multi-turn	EQN 1325	
	FB = Optical EnDat SinCos Single-turn	ECN 1313	
	XX = Specials		

²not available on 055 frame

• Other feedback options are available on request but may increase the motor lead time. Please check before ordering.

Frame size 055

Motor frame size (mm)		055ED			055UD		
Voltage (Vrms)		200-240			380-480		
Frame length		A	B	C	A	B	C
Continuous stall torque (Nm)		0.72	1.18	1.65	0.72	1.18	1.65
Peak torque (Nm)		2.88	4.72	6.60	2.88	4.72	6.60
Standard inertia (kg cm ²)		0.14	0.25	0.36	0.14	0.25	0.36
Winding thermal time constant (sec)		34	38	42	34	38	42
Standard motor weight (kg)		1.20	1.50	1.80	1.20	1.50	1.80
Number of poles		8	8	8	8	8	8
Speed 3000 (rpm)	Kt (Nm/A) =	0.74	0.87	0.91	0.74	1.49	1.65
	Ke (V/krpm) =	45	52.5	55	45	90	100
Rated torque (Nm)		0.70	1.05	1.48	0.70	1.05	1.48
Stall current (A)		0.97	1.36	1.81	0.97	0.79	1.00
Rated power (kW)		0.22	0.33	0.46	0.22	0.33	0.46
R (ph-ph) (Ohms)		28	14.12	9.53	28	45	31
L (ph-ph) (mH)		50	32	23	50	100	75
Recommended power conn' size		1	1	1	1	1	1
Speed 6000 (rpm)	Kt (Nm/A) =	0.45	0.43	0.48	0.74	0.79	0.83
	Ke (V/krpm) =	27	26	29	45	47.50	50
Rated torque (Nm)		0.68	0.9	1.2	0.68	0.9	1.2
Stall current (A)		1.61	2.74	3.44	0.97	1.49	1.99
Rated power (kW)		0.43	0.57	0.75	0.43	0.57	0.75
R (ph-ph) (Ohms)		8.5	3.55	2.38	28	10.7	7.8
L (ph-ph) (mH)		16	8.2	6.3	50	25	20
Recommended power conn' size		1	1	1	1	1	1

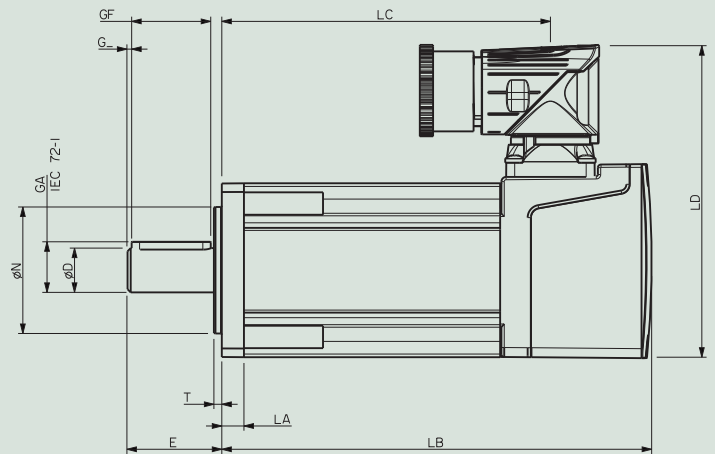
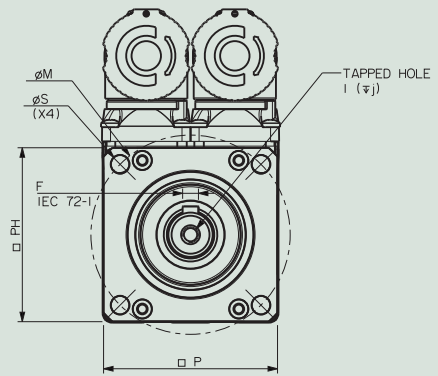

At= 100°C winding 40°C maximum ambient
All data subject to +/-10% tolerance
Stall torque, rated torque and power relate to maximum continuous operation tested in a 20°C ambient at 12 kHz drive switching frequency
All other figures relate to a 20°C motor temperature.
Maximum intermittent winding temperature is 140°C

Motor dimension (mm)

Drawing number: GM496400

	Feedback AR, CR, EM/FM				Flange thickness	Register length	Register diameter	Overall height	Flange square	Fixing hole diameter	Fixing hole PCD	Motor housing	Mounting bolts
	Unbraked length		Braked length										
	LB (±0.9)	LC (±1.0)	LB (±0.9)	LC (±1.0)									
055A	118.0	90.0	158.0	130.0	7.0	2.5	40.0	99.0	55.0	5.8	63.0	55.0	M5
055B	142.0	114.0	182.0	154.0									
055C	166.0	138.0	206.0	178.0									

Shaft dimensions (mm)

Shaft diameter	Shaft length	Key height	Key length	Key to shaft end	Key width	Tapped hole thread size	Tapped hole depth	
D (j6)	E	GA	GF	G	F (h9)	I	J (±1)	
14.0 Std	14	30.0	16.0	25.0	1.5	5.0	M5	12.5

Frame size 067

Motor frame size (mm)		067ED			067UD		
Voltage (Vrms)		200-240			380-480		
Frame length		A	B	C	A	B	C
Continuous stall torque (Nm)		1.45	2.55	3.70	1.44	2.55	3.7
Peak torque (Nm)		4.35	7.65	11.10	4.35	7.65	11.1
Standard inertia (kg cm ²)		0.30	0.53	0.75	0.3	0.53	0.75
Winding thermal time constant (sec)		54.0	61.0	65.0	54	61.0	65.0
Standard motor weight (kg)		1.96	2.56	3.16	1.96	2.56	3.16
Number of poles		10	10	10	10	10	10
Speed 3000 (rpm)	Kt (Nm/A) =	0.93			0.8	1.6	
	Ke (V/krpm) =	57			49	98	
Rated torque (Nm)		1.4	2.45	3.5	1.4	2.45	3.5
Stall current (A)		1.56	2.74	3.98	1.81	1.59	2.31
Rated power (kW)		0.44	0.77	1.1	0.44	0.77	1.1
R (ph-ph) (Ohms)		14.92	4.88	3.33	11.69	15.2	10.7
L (ph-ph) (mH)		45.4	17.4	12.7	35.2	54.2	40.8
Recommended power conn' size		1	1	1	1	1	1
Speed 6000 (rpm)	Kt (Nm/A) =	0.47			0.8		
	Ke (V/krpm) =	28.5			49		
Rated torque (Nm)		1.3	2.2		1.30	2.2	3.1
Stall current (A)		3.09	5.43		1.81	3.19	4.63
Rated power (kW)		0.82	1.38		0.82	1.38	1.95
R (ph-ph) (Ohms)		3.86	1.22		11.69	3.79	2.68
L (ph-ph) (mH)		11.1	4.4		35.2	13.6	10.2
Recommended power conn' size		1	1		1	1	1

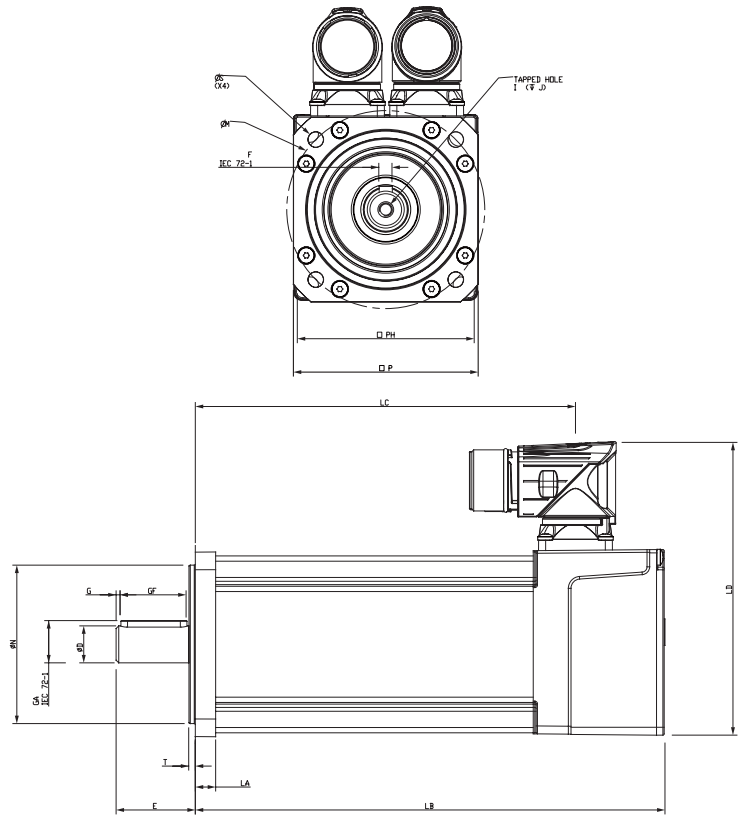

Δt= 100°C winding 40°C maximum ambient
 All data subject to +/-10% tolerance
 Stall torque, rated torque and power relate to maximum continuous operation tested in a 20°C ambient at 12kHz drive switching frequency
 All other figures relate to a 20°C motor temperature.
 Maximum intermittent winding temperature is 140°C

Motor dimension (mm)

Drawing number: IM/0694/GA

	Feedback AR, CR, EM/FM				Flange thickness	Register length	Register diameter	Overall height	Flange square	Fixing hole diameter	Fixing hole PCD	Motor housing	Mounting bolts
	Unbraked length		Braked length										
	LB (± 0.9)	LC (± 1.0)	LB (± 0.9)	LC (± 1.0)									
067A	142.9	109.0	177.9	144.0	7.7	2.5	60.0	111.5	70.0	5.8	75.0	67.00	M5
067B	172.9	139.0	207.9	174.0									
067C	202.9	169.0	237.9	204.0									

	Feedback TL/UL	
	Unbraked length	Braked length
	LB (± 0.9)	LB (± 0.9)
067A	157.4	123.5
067B	187.4	153.5
067C	217.4	183.5

Shaft dimensions (mm)

	Shaft diameter	Shaft length	Key height	Key length	Key to shaft end	Key width	Tapped hole thread size	Tapped hole depth
	D (j6)	E	GA	GF	G	F (h9)	I	J (± 1)
14.0 (Std)	14.0	30.0	16.0	25.0	1.5	5.0	M5 x 0.8	13.5

Frame size 089

Motor frame size (mm)		089ED			089UD		
Voltage (Vrms)		200-240			380-480		
Frame length		A	B	C	A	B	C
Continuous stall torque (Nm)		3.2	5.5	8.0	3.2	5.5	8.0
Peak torque (Nm)		9.6	16.5	24.0	9.6	16.5	24.0
Standard inertia (kg cm ²)		0.87	1.61	2.34	0.87	1.61	2.34
Winding thermal time constant (sec)		85.0	93.0	98.0	85	93.0	98.0
Standard motor weight (kg)		3.18	4.28	5.38	3.18	4.28	5.38
Number of poles		10	10	10	10	10	10
Speed 3000 (rpm)	Kt (Nm/A) =	0.93			1.6		
	Ke (V/krpm) =	57			98		
Rated torque (Nm)		3.0	4.85	6.9	3	4.85	6.9
Stall current (A)		3.44	5.91	8.6	2	3.44	5.0
Rated power (kW)		0.94	1.52	2.17	0.94	1.52	2.17
R (ph-ph) (Ohms)		3.28	1.57	0.89	10.1	5.05	2.68
L (ph-ph) (mH)		21.6	11.8	7.1	65.2	38.4	21.7
Recommended power conn' size		1	1	1	1	1	1
Speed 4000 (rpm)	Kt (Nm/A) =	0.7			1.2		
	Ke (V/krpm) =	42.75			73.5		
Rated torque (Nm)		2.9	4.55	6.35	2.9	4.55	6.35
Stall current (A)		4.57	7.86	11.4	2.67	4.58	6.67
Rated power (kW)		1.21	1.91	2.66	1.21	1.91	2.66
R (ph-ph) (Ohms)		2.04	0.79	0.54	6.16	2.47	1.75
L (ph-ph) (mH)		13.2	6.0	4.4	39.8	18.8	14.0
Recommended power conn' size		1	1	1	1	1	1
Speed 6000 (rpm)	Kt (Nm/A) =	0.47			0.8		
	Ke (V/krpm) =	28.5			49		
Rated torque (Nm)		2.65	3.8	5.0	2.65	3.8	5.0
Stall current (A)		6.81	11.7	17.02	4.0	6.88	10.0
Rated power (kW)		1.67	2.39	3.14	1.67	2.39	3.14
R (ph-ph) (Ohms)		0.98	0.39	0.23	2.52	1.27	0.83
L (ph-ph) (mH)		6.2	3.0	1.90	16.3	9.6	6.7
Recommended power conn' size		1	1	1	1	1	1

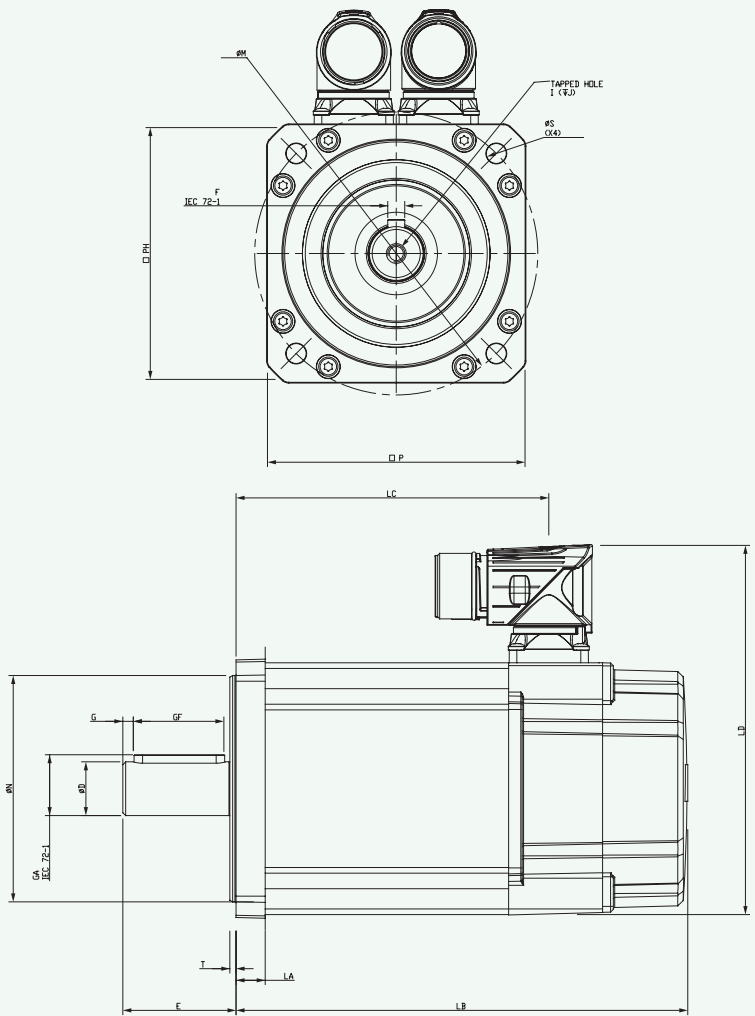

At= 100°C winding 40°C maximum ambient
All data subject to +/-10% tolerance
Stall torque, rated torque and power relate to maximum continuous operation tested in a 20°C ambient at 12kHz drive switching frequency
All other figures relate to a 20°C motor temperature.
Maximum intermittent winding temperature is 140°C

Motor dimension (mm)

Drawing number: IM/0688/GA

	Feedback EC/FC, LC/NC				Flange thickness	Register length	Register diameter	Overall height	Flange square	Fixing hole diameter	Fixing hole PCD	Motor housing	Mounting bolts
	Unbraked length		Braked length										
	LB (± 0.9)	LC (± 1.0)	LB (± 0.9)	LC (± 1.0)									
089A	147.8	110.5	187.9	150.6	10.3	2.2	80.0	130.5	91.0	7.00	100.0	89.0	M6
089B	177.8	140.5	217.9	180.6									
089C	207.8	170.5	247.9	210.6									

	Feedback FB, EB/CA/SA, RA		Feedback AE	
	Unbraked length	Braked length	Unbraked length	Braked length
	LB (± 0.9)	LB (± 0.9)	LB (± 0.9)	LB (± 0.9)
089A	160.8	200.9	137.8	177.9
089B	190.8	230.9	167.8	207.9
089C	220.8	260.9	197.8	237.9

Shaft dimensions (mm)

	Shaft diameter	Shaft length	Key height	Key length	Key to shaft end	Key width	Tapped hole thread size	Tapped hole depth
	D (j6)	E	GA	GF	G	F (h9)	I	J (± 1)
19.0 Std	19.0	40.0	21.5	32.0	3.7	6.0	M6 x 1.0	17.0

Frame size 115

Motor frame size (mm)		115ED			115UD		
Voltage (Vrms)		200-240			380-480		
Frame length		B	C	D	B	C	D
Continuous stall torque (Nm)		10.2	14.6	18.8	10.2	14.6	18.8
Peak torque (Nm)		30.6	43.8	56.4	30.6	43.8	56.4
Standard inertia (kg cm ²)		4.41	6.39	8.38	4.41	6.39	8.38
Winding thermal time constant (sec)		164.0	168.0	175.0	164	168.0	175.0
Standard motor weight (kg)		6.95	8.7	10.49	6.95	8.72	10.49
Number of poles		10	10	10	10	10	10
Speed 2000 (rpm)	Kt (Nm/A) =	1.4			2.4		
	Ke (V/krpm) =	85.5			147		
Rated torque (Nm)		8.6	11.90	15.6	8.6	11.90	15.6
Stall current (A)		7.29	10.43	13.43	4.25	6.08	7.83
Rated power (kW)		1.80	2.49	3.27	1.8	2.49	3.27
R (ph-ph) (Ohms)		1.40	0.77	0.61	4.41	2.41	1.8
L (ph-ph) (mH)		12.8	7.9	6.6	40.6	24.7	19.5
Recommended power conn' size		1	1	1	1	1	1
Speed 3000 (rpm)	Kt (Nm/A) =	0.93			1.6		
	Ke (V/krpm) =	57			98		
Rated torque (Nm)		7.7	10.5		7.7	10.5	13.6
Stall current (A)		10.97	15.70		6.38	9.13	11.75
Rated power (kW)		2.42	3.30		2.42	3.3	4.27
R (ph-ph) (Ohms)		0.58	0.39		1.83	1.21	0.78
L (ph-ph) (mH)		5.4	4.0		16.9	12.7	8.7
Recommended power conn' size		1	1		1	1	1

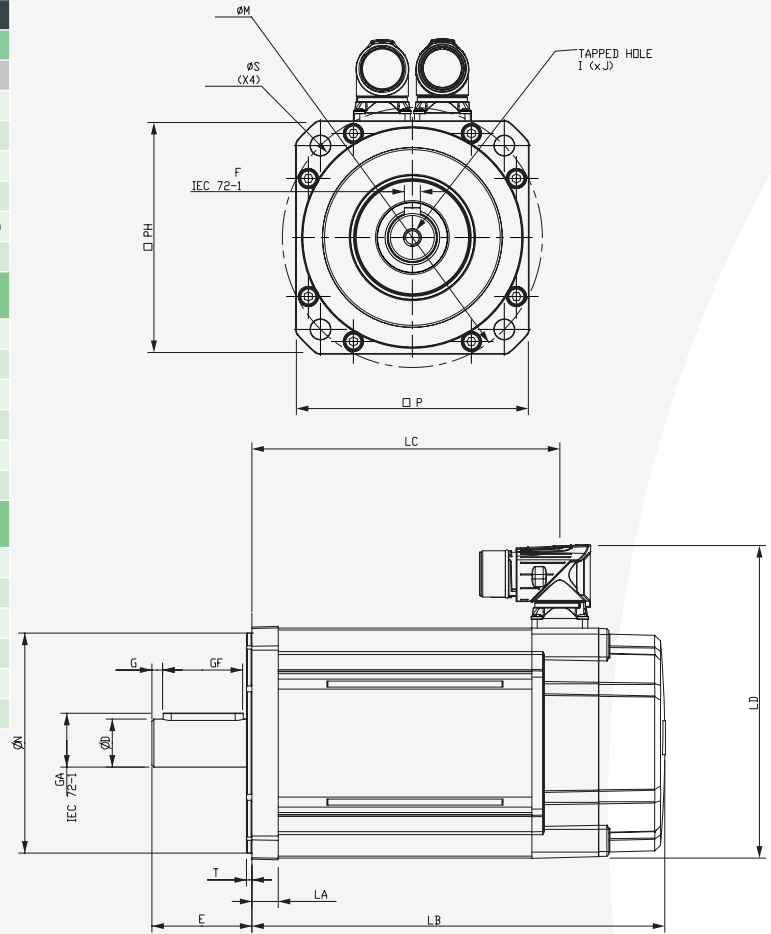

Δt= 100°C winding 40°C maximum ambient
 All data subject to +/-10% tolerance
 Stall torque, rated torque and power relate to maximum continuous operation tested in a 20°C ambient at 12kHz drive switching frequency
 All other figures relate to a 20°C motor temperature.
 Maximum intermittent winding temperature is 140°C

Motor dimension (mm)

Drawing number: IM/0689/GA

	Feedback EC/FC, LC/NC				Flange thickness	Register length	Register diameter	Overall height	Flange square	Fixing hole diameter	Fixing hole PCD	Motor housing	Mounting bolts
	Unbraked length		Braked length										
	LB (± 0.9)	LC (± 1.0)	LB (± 0.9)	LC (± 1.0)									
115B	193.8	154.0	230.9	191.1	13.2	2.7	110.0	156.5	116.0	10.00	130.0	115.0	M8
115C	223.8	184.0	260.9	221.1									
115D	253.8	214.0	290.9	251.1									

	Feedback FB, EB/CA/SA, RA		Feedback AE	
	Unbraked length	Braked length	Unbraked length	Braked length
	LB (± 0.9)	LB (± 0.9)	LB (± 0.9)	LB (± 0.9)
115B	206.8	243.9	183.8	220.9
115C	236.8	273.9	213.8	250.9
115D	266.8	303.9	243.8	280.9

Shaft dimensions (mm)

	Shaft diameter	Shaft length	Key height	Key length	Key to shaft end	Key width	Tapped hole thread size	Tapped hole depth
	D (j6)	E	GA	GF	G	F (h9)	I	J (± 0.1)
24.0 Std	24.0	50.0	27.0	40.0	5.3	8.0	M8 x 1.25	20.0

Frame size 142

Motor frame size (mm)		142ED			142UD		
Voltage (Vrms)		200-240			380-480		
Frame length		C	D	E	C	D	E
Continuous stall torque (Nm)		25.0	31.5	38.0	25.0	31.5	38.0
Peak torque (Nm)		74.9	94.5	114.0	74.9	94.5	114.0
Standard inertia (kg cm ²)		17.0	22.1	27.2	17.0	22.10	27.20
Winding thermal time constant (sec)		245.0	251.0	256.0	245.0	251.0	256.0
Standard motor weight (kg)		12.74	15.39	18.04	12.74	15.39	18.04
Number of poles		10	10	10	10	10	10
Speed 1000 (rpm)	Kt (Nm/A) =	2.8					
	Ke (V/krpm) =	171					
Rated torque (Nm)		23.3	29.0	34.5			
Stall current (A)		8.9	11.2	13.6			
Rated power (kW)		2.44	3.04	3.61			
R (ph-ph) (Ohms)		1.36	0.94	0.72			
L (ph-ph) (mH)		21.3	15.2	12.3			
Recommended power conn' size		1	1	1			
Speed 1500 (rpm)	Kt (Nm/A) =				3.2		
	Ke (V/krpm) =				196		
Rated torque (Nm)					22.3	27.0	31.7
Stall current (A)					7.80	9.8	11.9
Rated power (kW)					3.50	4.2	5.0
R (ph-ph) (Ω)					1.36	0.94	0.72
L (ph-ph) (mH)					21.3	15.2	12.3
Connection type					1	1	1
Speed 2000 (rpm)	Kt (Nm/A) =	1.4			2.4		
	Ke (V/krpm) =	85.5			147		
Rated torque (Nm)		21.4	25.7	29.6	21.4	25.7	29.6
Stall current (A)		17.8	22.5	27.1	10.4	13.1	15.8
Rated power (kW)		4.48	5.38	6.2	4.48	5.38	6.20
R (ph-ph) (Ohms)		0.34	0.24	0.18	0.79	0.62	0.49
L (ph-ph) (mH)		5.3	3.8	3.1	12.2	9.7	8.3
Recommended power conn' size		1.5	1.5	1.5	1	1	1
Speed 3000 (rpm)	Kt (Nm/A) =	0.93			1.6		
	Ke (V/krpm) =	57			98		
Rated torque (Nm)		18.4	20.9		18.4	20.9	23
Stall current (A)		26.9	33.9		15.6	19.7	23.8
Rated power (kW)		5.78	6.57		5.78	6.57	7.23
R (ph-ph) (Ohms)		0.12	0.1		0.34	0.24	0.18
L (ph-ph) (mH)		1.9	1.6		5.3	3.8	3.1
Recommended power conn' size		1.5	1.5		1	1.5	1.5

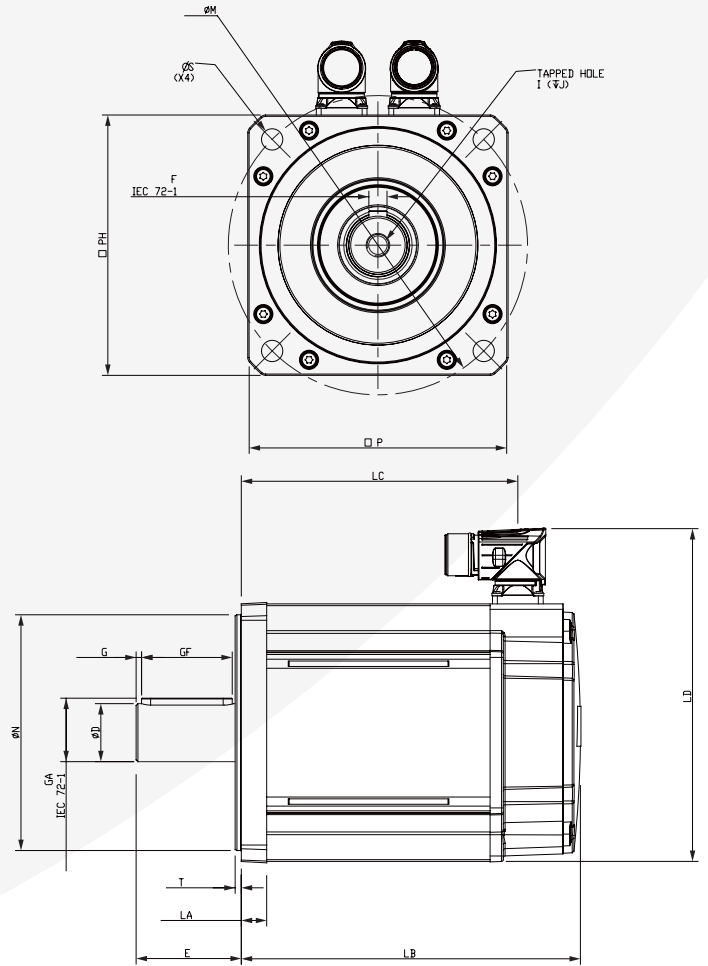

At= 100°C winding 40°C maximum ambient. All data subject to +/-10% tolerance
 Stall torque, rated torque and power relate to maximum continuous operation tested in a 20°C ambient at 12kHz drive switching frequency
 All other figures relate to a 20°C motor temperature. Maximum intermittent winding temperature is 140°C

Motor dimension (mm)

Drawing number: IM/0709/GA

	Unbraked length		Braked length		Flange thickness	Register length	Register diameter	Overall height	Flange square	Fixing hole diameter	Fixing hole PCD	Motor housing	Mounting bolts
	LB (± 0.9)	LC (± 1.0)	LB (± 0.9)	LC (± 1.0)									
142C	217.0	182.5	282.5	248.0	14.0	3.4	130.0	183.5	142.0	12.0	165.0	142.0	M10
142D	247.0	212.5	312.5	278.0				183.5-					
142E	277.0	242.5	342.5	308.0				204.5					

Shaft dimensions (mm)

	Shaft diameter	Shaft length	Key height	Key length	Key to shaft end	Key width	Tapped hole thread size	Tapped hole depth
	D (j6)	E	GA	GF	G	F (h9)	I	J (± 1)
32.0 Std	32.0	58.0	35.0	50.0	3.0	10.0	M12 x 1.75	29.0

Frame size 190

Motor frame size (mm)		190ED			190UD		
Voltage (Vrms)		200-240			380-480		
Frame length		C	D	F	C	D	F
Continuous stall torque (Nm)		52.0	62.0	85.0	52	62.0	85.0
Peak torque (Nm)		156.0	186.0	255.0	156	186.0	255.0
Standard inertia (kg cm ²)		54.6	70.9	103.5	54.6	70.9	103.5
Winding thermal time constant (sec)		311.0	316.0	324.0	311.0	316.0	324.0
Standard motor weight (kg)		27.74	34.3	47.42	27.74	34.3	47.42
Number of poles		10	10	10	10	10	10
Speed 1000 (rpm)	Kt (Nm/A) =	2.8					
	Ke (V/krpm) =	171					
Rated torque (Nm)		49.0	56.5	77.5			
Stall current (A)		18.6	22.1	30.4			
Rated power (kW)		5.13	5.92	8.12			
R (ph-ph) (Ohms)		0.47	0.4	0.23			
L (ph-ph) (mH)		12.3	10.4	6.8			
Recommended power conn' size		1.5	1.5	1.5			
Speed 1500 (rpm)	Kt (Nm/A) =				3.2		
	Ke (V/krpm) =				196		
Rated torque (Nm)					46.2	52.2	68.5
Stall current (A)					16.3	19.4	26.6
Rated power (kW)					7.26	8.2	10.76
R (ph-ph) (Ohms)					0.57	0.4	0.23
L (ph-ph) (mH)					14.2	10.4	6.8
Recommended power conn' size					1.5	1.5	1.5
Speed 2000 (rpm)	Kt (Nm/A) =	1.4			2.4		
	Ke (V/krpm) =	85.5			147		
Rated torque (Nm)		42.5			42.5	45.3	56.0
Stall current (A)		37.14			21.7	25.8	35.42
Rated power (kW)		8.9			8.9	9.5	11.7
R (ph-ph) (Ohms)		0.12			0.34	0.17	0.14
L (ph-ph) (mH)		3.1			8.2	5.05	4.55
Recommended power conn' size		1.5			1.5	1.5	1.5

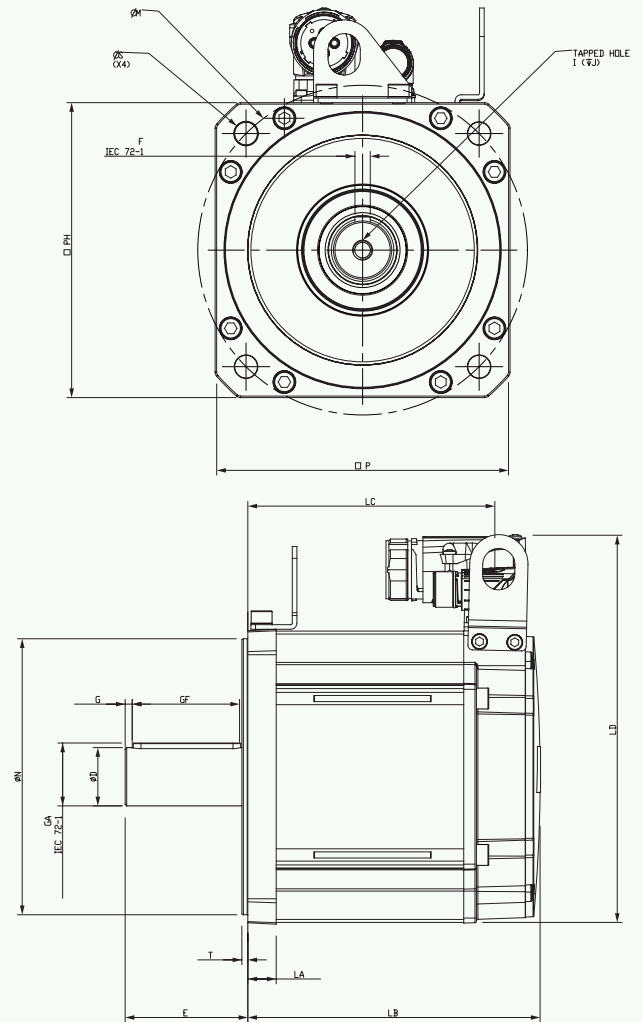

At= 100°C winding 40°C maximum ambient. All data subject to +/-10% tolerance
 Stall torque, rated torque and power relate to maximum continuous operation tested in a 20°C ambient at 6kHz drive switching frequency
 All other figures relate to a 20°C motor temperature. Maximum intermittent winding temperature is 140°C

Motor dimension (mm)

Drawing number: IM/00710/GA

	Unbraked length		Braked length		Flange thickness	Register length	Register diameter	Overall height	Flange square	Fixing hole diameter	Fixing hole PCD	Motor housing	Mounting bolts
	LB (± 0.9)	LC (± 1.0)	LB (± 0.9)	LC (± 1.0)									
190C	220.6	191.1	319.1	289.6	18.5	3.9	180.0	252.5	190.3	14.5	215.0	190.0	M12
190D	250.6	221.1	349.1	319.6									
190F	310.6	281.1	409.1	379.6									

Shaft dimensions (mm)

	Shaft diameter	Shaft length	Key height	Key length	Key to shaft end	Key width	Tapped hole thread size	Tapped hole depth
	D (j6)	E	GA	GF	G	F (h9)	I	J (± 1)
38.0 Std	38.0	80.0	41.0	70.0	4.6	10.0	M12 x 1.75	29.0

Motor derating

Any adverse operating conditions require that the motor performance be derated. These conditions include: ambient temperature above 40 °C, motor mounting position, drive switching frequency or the drive being oversized for the motor.

Ambient temperatures

The ambient temperature around the motor must be taken into account. For ambient temperatures above 40 °C the torque must be derated using the following formula as a guideline. (Note: Only applies to 2,000/3,000 rpm motors and assumes copper losses dominate.)

New derated torque
 = Specified torque × $\sqrt{1 - ((\text{Ambient temperature} - 40^\circ\text{C}) / 100)}$

For example with an ambient temperature of 76 °C the new derated torque will be 0.8 x specified value

Thermal test conditions

The performance data shown has been recorded under the following conditions. Ambient temperature 20 °C, with the motor mounted on a thermally isolated aluminium plate as shown below.

Mounting arrangements

The motor torque must be derated if:

- The motor mounting surface is heated from an external source, such as a gearbox.
- The motor is connected to a poor thermal conductor.
- The motor is in a confined space with restricted air flow.

Drive switching frequency

Most Unidrive M and Digitax ST nominal current ratings are reduced for the higher switching frequencies. See the appropriate drive manual for details.

See the table below for the motor derate factors. These figures are for guidance only.

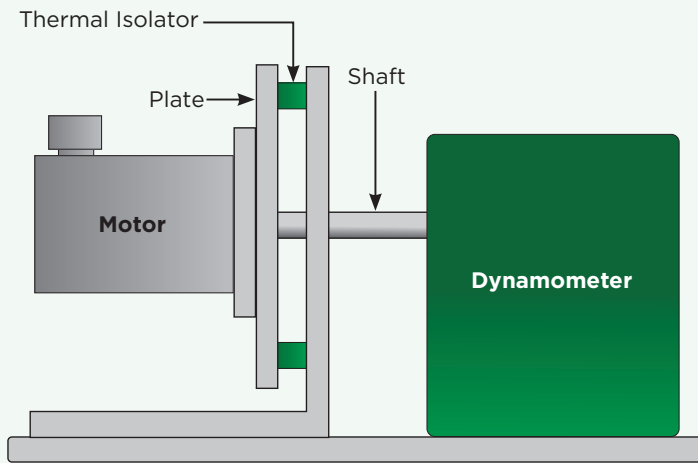

Motor type/frame	Aluminium heatsink plate
055 mm	110 x 110 x 27
067-089 mm	250 x 250 x 15mm
115-142 mm	350 x 350 x 20mm
190 mm	500 x 500 x 20mm

UNIMOTOR HD DERATE FACTORS

Switching frequency	Motor Frame					
	055	067	089	115	142	190
3kHz	0.92	0.93	0.89	0.89	0.83	0.90
4kHz	0.93	0.94	0.91	0.92	0.92	0.95
6kHz	0.95	0.95	0.95	0.96	0.96	1
8kHz	0.96	0.98	0.97	0.98	0.98	1
12/16kHz	1	1	1	1	1	1

NOTE: Only applies to motors up to 3,000 rpm (rms) or lower. Assumes copper losses dominate on all frame sizes. Derate factor is applied to stall torque, rated torque, stall current and rated power.

Performance definitions

Stall torque

This is the maximum torque within the continuous zone at zero speed. Maximum continuous torque ratings may be intermittently exceeded for short periods provided that the winding Δt max temperature is not exceeded.

Δt max = 100 °C over a maximum ambient of 40 °C for Unimotor FM and Unimotor hd.

Stall current

Stall current = Stall torque / k_t

Motor label and performance tables quote stall current when motor is at full power in a maximum ambient of 40 °C.

Rated speed

This is the maximum speed of the motor within the continuous zone. The motor speed can be controlled to any speed subject to the voltage limits and drive constraints as shown by the intermittent zone on a motor performance graph

Ke voltage constant

This is the phase to phase rms voltage generated at the stator when the shaft is back driven at 1,000 rpm with the rotor at 20 °C.

Kt torque constant

A brushless motor delivers torque proportional to the current, such that torque = $K_t \times$ current.

Where $K_t = 0.0165 \times K_e$ (at 20 °C).

Magnets used on all motors are affected by temperature such that K_e and K_t reduce with increasing temperatures of the magnets. The reductions depends upon the magnet type and material grade used.

Winding thermal time constant

The thermal time constant of the winding with respect to the stator temperature as a reference in the exponential temperature rise given by the formula:

Winding temperature at time t seconds = $T_0 + T_1(1 - e^{-t/t_c})$

Where T_0 is the initial temperature, T_1 is the final winding temperature and t_c = thermal time constant (seconds)

Note that temperature = 63.2 % of T_1 when $t = t_c$

A thermal protection trip is provided by the drive, based upon calculations using elapsed time, current measurement, and the parameter settings set by the user or directly from the motor map.

Unimotor hd windings are ultimately protected by thermistor devices in the winding overhangs. These must be connected to the appropriate drive inputs via the motor feedback signal connector.

Rated power

This is the product of the rated speed (radian/sec) and the rated torque (Nm) expressed in Watts (W).

Δt temperature

Δt temperature is the temperature difference between the copper wires of the motor winding and the ambient air temperature surrounding the motor.

The maximum Δt temperature permitted is 100 °C over a maximum ambient of 40 °C.

(i.e. a maximum winding temperature of 140 °C)

Nameplate definitions

Model Full part number of the motor

3Ø Indicates this is a 3 phase motor

POLE Number of poles: 055 – 8 poles – 4 pole pairs 067-190 – 10 poles – 5 pole pairs

Insul Windings are built to class F (155 °C)

F/B This gives the feedback device, count and working voltage or the feedback type

S/N/DATE The serial number and date the motor was manufactured

IP Ingress protection rating IP 65S

Mcs The stall torque at stall current

Mn The rated torque of the motor

Ke This is the AC Volts per 1,000 rpm with the motor at 20 °C

Kt Value shown is for the magnet's temperature at 20 °C

Ics The constant stall current at the maximum winding temperature of 140 °C

Pn The rated power of the motor

nN/max The rated speed/ this is the maximum speed allowed when taking into account these three factors:

- 1) Maxdrive voltage
- 2) Maxencoder speed
- 3) Maxmechanical speed

VPWM This indicates that the motor is for use with a voltage pulse width modulated drive with the supply voltage shown

Brake The current, that rated torque and the operation voltage for the brake or N/A if the brake is not fitted

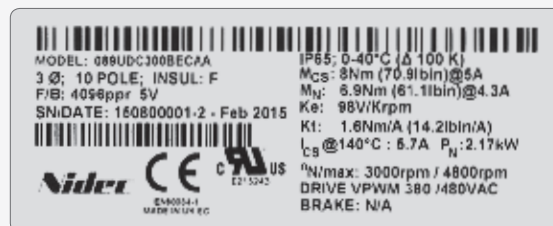

Additional motor weights all figures are subject to a tolerance of (±10%)

Motor frame size	055			067			089			115			142			190		
Frame length	A	B	C	A	B	C	A	B	C	A	B	C	A	B	C	A	B	C
Braked '5' brake	+0.4			+0.7			+1.0			+1.5			+2.8			+4.0		
Braked '6' brake				+0.68			+1.4			+2.09			+2.29					
Fan box										+1.65			+1.9			+2.6		
Hybrid box small										+0.5			+0.5					
Hybrid box medium													+0.5			+0.5		
Hybrid box large																+1.5		

Feedback

Feedback device order code	Feedback type	Manufacturer	Encoder supply voltage	SinCos cycle or incremental pulses per revolution	Resolution available to position loop ^{2,3}	Absolute multi-turn revolutions	Feedback accuracy ¹	Serial communication protocol	Frame size available
055 - 067 motors									
AR	Resolver	LTN RE - 15	7 Vdc Excitation 5kHz	1 Transformation ratio 0.5	Medium 16384 (14 bits)	-	Low +/- 600"	-	-
CR	Incremental Encoder	R35i	5 Vdc ± 10%	4096	Medium 16384 (14 bits)	-	Medium +/- 150"	-	-
TL (Multi-turn)	Optical Hiperface SinCos	SKM 36	7 - 12 Vdc	128	High 1.31 x 10 ⁵ (17 bits)	4096 (12 bits)	Medium +/- 120"	Hiperface	-
UL (Single-turn)		SKS 36			-				
EM (Multi-turn)	Inductive EnDat SinCos	EQI 1130	5 Vdc ± 5%	16	High 2.62 x 10 ⁵ (18 bits)	4096 (12 bits)	Low +/- 480"	EnDat 2.2 / EnDat 01	-
FM (Single-turn)		ECI 1118			-				
089 - 190 motors									
AE	Resolver	Size 52	6 Vdc Excitation 6kHz	1 Transformation ratio 0.31	Medium 16384 (14 bits)	-	Low +/- 720"	-	-
CA	Incremental Encoder	CFS50	5 Vdc ± 10%	4096	Medium 16384 (14 bits)	-	High +/- 60"	-	-
EC (Multi-turn)	Inductive EnDat SinCos	EQI 1331	4.75 - 10 Vdc	32	High 5.24 x 10 ⁵ (19 bits)	4096 (12 bits)	Medium +/- 380"	EnDat 2.2 / EnDat 01	-
FC (Single-turn)		ECI 1319			-				
EF (Multi-turn)	Inductive EnDat Functional Safety	EQI 1331 FS	3.60 - 14 Vdc	Serial Only	High 5.24 x 10 ⁵ (19 bits)	4096 (12 bits)	High +/- 65"	EnDat 2.2 / EnDat 22	-
FF (Single-turn)		ECI 1319 FS			-				
RA (Multi-turn)	Optical Hiperface SinCos	SRM 50	7 - 12 Vdc	1024	High 1.04 x 10 ⁶ (20 bits)	4096 (12 bits)	High +/- 52"	Hiperface	-
SA (Single-turn)		SRS 50			-				
EB (Multi-turn)	Optical EnDat SinCos	EQN 1325	3.6 - 14 Vdc	2048	High 2.08 x 10 ⁶ (21 bits)	4096 (12 bits)	Very High +/- 20"	EnDat 2.2 / EnDat 01	-
FB (Single-turn)		ECN 1313			-				

¹The information is supplied by the feedback device manufacturer and relates to it as a standalone device. The value may change when mounted into the motor and connected to a drive. These values have not been verified by Control Techniques.

²The output from the resolver is an analogue output; the resolution is determined by the analogue to digital converter used; the value shown is when the resolver is used in conjunction with the SM-Resolver

³The sin and cosine outputs from the SinCos optical encoders are analogue outputs; with Unidrive M and Digitax ST the resolutions quoted above are when the encoder type is set to either SC EnDat or SC Hiperface depending on the encoder.

Feedback terminology

Resolver

A passive wound device consisting of a stator and rotor elements excited from an external source, such as an SM-Resolver, the resolver produces two output signals that correspond to the Sine and CoSine angle of the motor shaft. This is a robust absolute device of low accuracy, capable of withstanding high temperature and high levels of vibration. Positional information is absolute within one turn – i.e. position is not lost when the drive is powered down.

Incremental encoder

An electronic device using an optical disc. The position is determined by counting steps or pulses. Two sequences of pulses in quadrature are used so the direction sensing may be determined and 4x (pulses per rev) may be used for resolution in the drive. A marker pulse occurs once per revolution and is used to zero the position count. The encoder also provides commutation signals, which are required to determine the absolute position during the motor phasing test. This device is available in 4096, 2048 and 1024 ppr versions. Positional information is non absolute – i.e. position is lost when the drive is powered down.

SinCos / absolute encoders

Types available are: Optical or Inductive – which can be single or multi-turn.

1) Optical

An electronic device using an optical disc. An absolute encoder with high resolution that employs a combination of absolute information, transmitted via a serial link, and Sine/CoSine signals with incremental techniques.

2) Inductive/Capacitive

An electronic device using inductively coupled PCBs. An absolute encoder with medium resolution the employs a combination of absolute information, transmitted via a serial link, and Sine/CoSine signals with incremental techniques. This encoder can be operated with the drive using either Sine/CoSine or absolute (serial) values only. Positional information is absolute within 4096 turns – i.e. position is not lost when the drive is powered down.

Multi-turn

As previous but with extra gear wheels included so that the output is unique for each shaft position and the encoder has the additional ability to count complete turns of the motor shaft up to 4096 revolutions

Electronic nameplate

Available on some feedback devices the electronic nameplate provides the facility to store information about the motor and feedback device. This information can then automatically be used to configure the drive for operation.

Environment

The environment is the external conditions that physically surround the Feedback device. The main factors that affect the feedback device are temperature and mechanical shock and vibration.

Motors are designed to allow the feedback devices to be within their operational temperature limits. Generally it is assumed that there is free air movement around the motor. If the motor is positioned where there is little or no airflow or it is connected to a heat source such as a gearbox, it can cause the air temperature around the feedback device to be operating outside its recommended operating temperature and can lead to problems.

Mechanical shock and vibration tends to be transmitted from the load through the motor shaft and into the feedback device. This should be considered when the motor and feedback device are being specified for the application.

Position

The defined position is the location in a coordinate system which is usually in two or more dimensions.

For a rotary feedback device this is defined as the location within one revolution. If it is a multi-turn device it is the location within one revolution plus the location within a number of rotations.

For a linear feedback device this is defined as the distance from a known point.

Resolution

The resolution of a feedback device is the smallest change in position or angle that it can detect in the quantity that it is measuring.

Feedback resolution of the system is a function of the type of feedback device used and drive receiving the information.

Generally, as the resolution of the feedback device increases the level of control that can be used in the servo system increases.

As with accuracy, as the resolution of the device increases the cost increases.

Accuracy

Accuracy is the measure of the difference between the expected position and actual measured value. Rotary feedback accuracy is usually given as an angle representing the maximum deviation from the expected position. Linear feedback accuracy is usually given as a distance representing the maximum deviation from the expected.

Generally, as the accuracy increases the cost of the feedback device increases.

Brake specification

Unimotor hd may be ordered with an internal rear mounted spring applied parking brake. The brake works on a failsafe principle. The brake is active when the supply voltage is switched off, and the brake is released when the supply voltage is switched on.

If a motor is fitted with a failsafe brake, take care not to subject the motor shaft to excessive torsional shocks or resonance when the brake is engaged or disengaged. Doing so can damage the brake.

Safety note

The failsafe brake is for use as a holding brake with the motor shaft stationary.

Do NOT use it as a dynamic brake. Using it in this manner will cause brake wear and eventual failure. Emergency Stop situations can contribute to brake wear and failure.



Note: Shunting the brake primary coil with an external diode to avoid switching peaks increases the release time considerably. This is usually required to protect solid state switches, or to reduce arcing at the brake relay contacts (Diode 1N4001 recommended)

“Resin” friction material application & benefits:

- The main features change to the type 6 brake is the use of an improved Resin friction material compared to its predecessors.
- The type 6 brake has improved overall performance in operation compared to the aluminium cored friction materials containing natural rubber.
- Type 6 brakes can endure higher interface temperatures and pressures.
- Type 6 brake disk are moulded as a one-piece part providing better tensile, compressive & impact qualities compared to other friction materials.

Unimotor hd

Motor frame	Supply volts	Input power	Static torque		Release time	Moment of inertia	Backlash **
			Parking Brake (5)				
Size	Vdc	Watts	Nm		ms nom	kg.cm ² *	Degrees **
055	24	6.3	1.8		22	0.03	0.73
067	24	10.2	4		<50	0.073	0.75
089	24	23	10		<50	0.115	0.75
115	24	23	20		120	0.21	0.75
142	24	25	42		95	1.85	0.77
190 (C-D)	24	25	67		120	4.95	0.77
190 F	24	54.5	100		TBA	7.72	0.75

Motor frame	Supply volts	Input power @ 20 °C	Static torque		Release time	Moment of inertia	Backlash **
			Parking Brake (6)				
Size	Vdc	Watts	Nm		ms nom	kg.cm ² *	Degrees **
067	24	15	2		35.2	0.063	0.62°
089	24	18.5	10		72.8	0.259	0.45°
115	24	17.5	16		64	0.506	0.38°
142	24	17.5	16		64	0.506	0.38°

*Note 1 kg.cm² = 1 x 10⁻⁴ kg.m² ** Backlash figure will increase with time

- The brake is intended for parking duty and is not for dynamic or safety use.
- Refer to your Automation Center or Distributor if your application requires dynamic braking in emergency conditions.
- To provide protection to the brake control circuit it is recommended that a diode is connected across the output terminals of the solid state or relay contacts devices.
- Larger torque brakes are available as an option. Contact your Automation Center or Distributor for details.
- Figures are shown at 20 °C brake temperature. Apply the derate factor of 0.9 to the high energy brake if motor temperature is above 100 °C.
- The brake will engage when power is removed.

It is recommended to run extensive application validation testing and confirm the motor brake life span when the motor is mounted vertically and the motor runs through high acceleration and deceleration.

Power plug

					
Size 1	With brake	Without brake	Size 1.5	With brake	Without brake
Pin	Function	Function	Pin	Function	Function
1	Phase U (R)	Phase U (R)	U	Phase U (R)	Phase U (R)
2	Phase V (S)	Phase V (S)	V	Phase V (S)	Phase V (S)
3	Ground	Ground	⊖	Ground	Ground
4	Phase W (T)	Phase W (T)	W	Phase W (T)	Phase W (T)
5	Brake		+	Brake	
6	Brake		-	Brake	
Shell	Screen	Screen	Shell	Screen	Screen

Signal plug

				
	Incremental encoder (CA, CR, MA)	Heidenhain Sincos absolute encoders (EM, FM, EC, EF, FF, FC, EB, FB)	Resolver (AE, AR)	SICK Sin/Cos encoders (RA, SA)
Pin	Function	Function	Function	Function
1	Thermistor	Thermistor	Excitation High	REF Cos
2	Thermistor	Thermistor	Excitation Low	+ Data
3		Screen (Optical only)	Cos High	- Data
4	S1		Cos Low	+ Cos
5	S1 Inverse		Sin High	+ Sin
6	S2		Sin Low	REF Sin
7	S2 Inverse		Thermistor	Thermistor
8	S3	+ Clock	Thermistor	Thermistor
9	S3 Inverse	- Clock		Screen
10	Channel A	+ Cos		0 Volts
11	Index	+ Data		-
12	Index Inverse	- Data		+ V
13	Channel A Inverse	- Cos		
14	Channel B	+ Sin		
15	Channel B Inverse	- Sin		
16	+ V	+ V		
17	0 Volts	0 Volts		
Body	Screen	Screen		Screen

Connect with us at:



www.controltechniques.com



© 2018 Nidec Control Techniques Limited. The information contained in this brochure is for guidance only and does not form part of any contract. The accuracy cannot be guaranteed as Nidec Control Techniques Ltd have an ongoing process of development and reserve the right to change the specification of their products without notice.

Nidec Control Techniques Limited. Registered Office: The Gro, Newtown, Powys SY16 3BE. Registered in England and Wales. Company Reg. No. 01236886.